

Power Stow Rollertrack Conveyor – at a glance

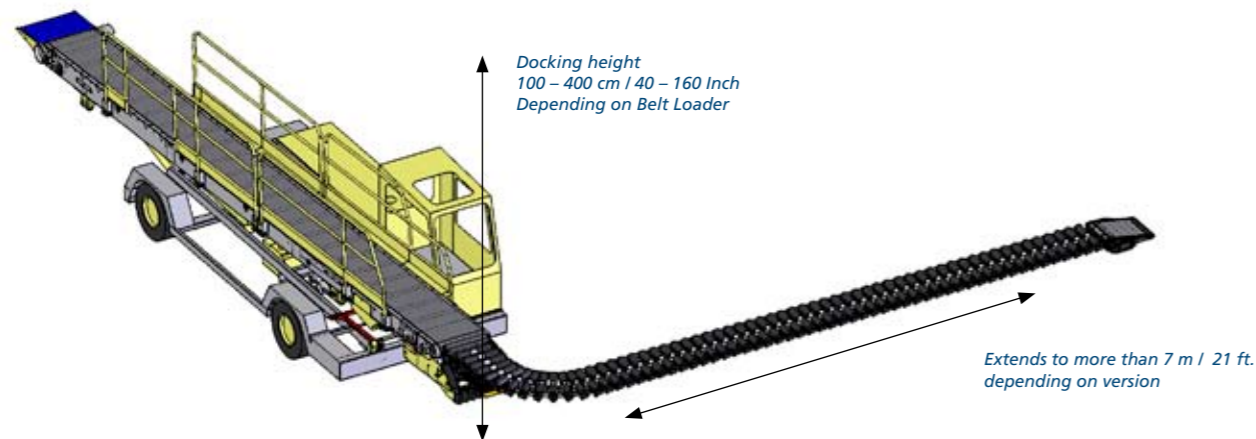

The Power Stow Rollertrack equipped Belt Loader can dock on any common plane.

The extension reaches to the end of the cargo hold

Extremely robust

Power Stow Rollertrack delivers the answers to a range of important operational issues.

Power Stow Rollertrack comes with a number of thoroughly considered features.

Each link is tested to 1000 N or 100 Kg / 220 pounds load. As the load is always distributed over several links, there is virtually no practical limit to the loads on the Rollertrack. Polyurethane Sh. 60 A wheels distributes the load evenly to the cargo hold floor.

The loading- / unloading head will stand more than a unit weight of 200 kg. / 440 pounds. A pneumatic system eases the movement of the loading- / unloading head.

The savings on manpower amount to at least 30 % giving you a fast pay-back time of 12 to 16 months.

The ergonomical advantages are priceless to your employees. However, less staff turnover, less absence and enhanced working conditions will measure on your bottom line.

By scrapping aircraft mounted solutions annual fuel savings between 40 and 80.000 USD can be obtained per aircraft.

An automatic counter to keep tabs on the number of items loaded.

Easy to understand service messages – and many more.



Power Stow Rollertrack is protected by the following patent numbers:

WO 94/21542: Parcel conveyor
WO 2006/074659: Conveyor guard
WO 2005/073110: Conveyor device

(List is not complete)

Power Stow A/S
Tjærebyvej 30 · Tjæreby
DK-4000 Roskilde · Denmark
Phone: +45 4631 1032
Fax: +45 4631 0152
info@powerstow.com

www.powerstow.com

Power Stow Rollertrack Conveyor



– a versatile, easy to operate and reliable belt loader extension



The Power Stow Rollertrack offers a long line of decisive benefits to ground support operations

- Big savings with fast pay back and reduced manpower requirements
- No need for expensive and heavy on-board loading systems
- Enhanced working environment with less physical strain
- Complete extendability and flexibility inside the hold for faster loading and unloading
- Special roller design for exceptional stability
- Easy-to-use, powered transportation, extension and retraction
- Robust, easy to service and maintain

Power Stow Rollertrack Conveyor

– a logical solution to a 40 year old problem



Power Stow Rollertrack solves the basic problem of guiding baggage **round a 90 ° corner left or right** to the end of the cargo hold and straight on to stacking in the hold.



The basic concept of the Rollertrack, **the double conical rollers** exposes a concave roller-surface to guide passenger baggage and cargo items of all shapes, sizes and weights between the cargo hold and the mobile belt conveyor on the ramp.



The Rollertrack can easily be pulled out or retracted as necessary by a single operator to bring the end as close as possible to the baggage in the hold. This means **far less physical strain** on the operators than in comparable systems as well as lower manpower requirement.



The conveyor height **adjusts automatically** to the shifting loads of the aircraft to ensure, that the flexramp between the conveyor and the aircraft remains horizontal.

Power Stow Rollertrack Conveyor

– the decisive advantages to your bottom line

Extremely fast and accurate docking procedure

Especially by short turn-around times, does the well defined and safe docking procedure of the Power Stow Rollertrack help the operator to meet the ever increasing demands from the airlines. All parts of the Power Stow Rollertrack in contact with the aircraft are covered with Polyurethane Sh 60 A rubber material.



Simple operation in only to handles

The fact, that the Power Stow Rollertrack is operated by only two intuitive handles will save you lots of training time and operational errors. A three way handle for movement of track and loading- / unloading head and a toggle switch for start, stop and speed of conveying is all the operator needs to attend to beyond his well known belt loader.



Reliable conveying with high versatility

The double conical design of the rollers and the ideal line curve of the Rollertrack chain enables a reliable conveying of all shapes and sizes. A patented rubber band secures, that no strap becomes entangled into the chain links. Each link is tested to 1000 N or 100 Kg / 220 pounds load. Any shape of item from the size of 20 x 20 cm / 8 x 8 Inches to boxes as large as the cargo door can be conveyed by Power Stow Rollertrack. Long items like skis or golf bags will convey nicely around the 90 ° corner.



Complete solution

Power Stow A/S delivers a complete solution on a belt loader of your choice. Electrical as well as diesel powered belt loaders can form the basis of a solution. This gives you advantages in the economy of your workshop. The Power Stow equipment is manufactured to going industry standards using known electrical and mechanical components, thus facilitating easy maintenance.

